



Features

- Fast Turn-On
- Built-In Active Current Limit Protection
- Thermal Shutdown
- Linear AC or DC Operation
- Low Power Consumption
- Clean, Bounce-Free Switching
- High Surge Capability
- Low Power Drive Requirements
- Surface Mount Version Available
- Tape & Reel Packaging Available

Applications

- Instrumentation
 - Automatic Tuning/Balancing
 - Analog Multiplex
- Peripherals
 - Automatic Tuning/Balancing
 - Transducer Driver
- Security
- Medical Equipment

Approvals

- UL 508 Pending

Description

The CPC1560 is a 1-Form-A (Single Pole, Normally Open) optically isolated MOSFET switch that provides fast turn-on of loads up to 600mA_{DC} in a DC-Only configuration, 300mA_{rms} in an AC/DC configuration; active current-limit circuitry; and 3750V_{rms} of I/O isolation.

Fast turn-on is accomplished with the use of an external charge storage capacitor that provides the necessary charge required by the internal switching MOSFETs. The device charges this capacitor, through bootstrap diodes, from the load voltage, thereby alleviating the need for an additional power supply.

The CPC1560 incorporates thermal shutdown circuitry for improved survivability in harsh environments, and is designed to pass regulatory voltage surge requirements when provided with appropriate over-voltage protection circuitry.

Designed specifically for environmentally demanding AC or DC applications, where printed circuit board space is at a premium and additional power supplies are not available, the CPC1560 is an ideal solution.

Ordering Information

Part	Description
CPC1560G	8-Pin, DIP Through-Hole (50/Tube)
CPC1560GS	8-Pin, Surface Mount (50/Tube)
CPC1560GSTR	8-Pin, Surface Mount (1000/Reel)

Figure 1. CPC1560 Block Diagram

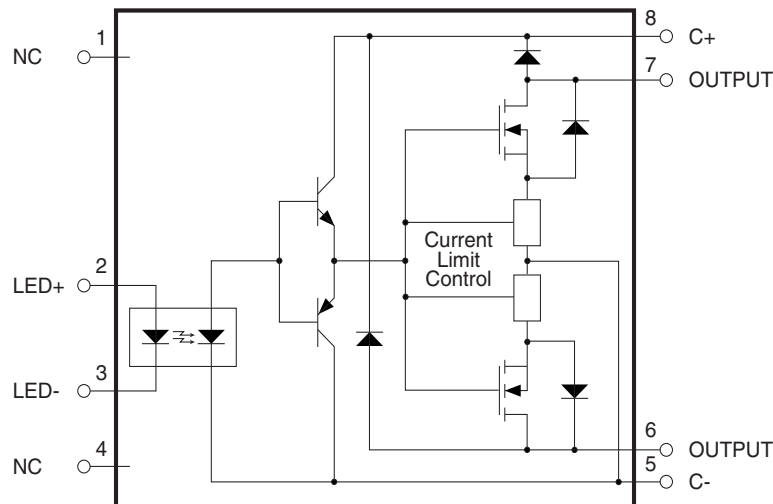

1. Specifications	3
1.1 Package Pinout	3
1.2 Pin Description	3
1.3 Absolute Maximum Ratings	3
1.4 ESD Rating	3
1.5 Recommended Operating Conditions	4
1.6 Typical Configurations	4
1.7 General Conditions	5
1.8 Electrical Specifications	5
1.9 Timing Diagram	5
1.10 Performance Data	6
2. Introduction	8
3. Functional Description	8
4. Device Configuration	8
4.1 LED Resistor	8
4.2 Storage Capacitor	9
5. Operational Behavior	9
5.1 Operating Frequency	9
5.1.1 Duty Cycle/Power Dissipation	9
5.1.2 Temperature Effects	9
5.1.3 Elements of Operating Frequency	9
5.2 Switching Losses	9
5.2.1 Effects of Ambient Temperature	10
5.3 Current Limit and Thermal Shutdown	10
5.3.1 Current Limit	10
5.3.2 Thermal Shutdown	10
5.4 dV/dt Fault Tolerance	10
5.5 Power Derating	10
5.6 Rise and Fall Times	11
5.7 Over-Voltage Protection	11
5.7.1 Stored Energy in the Load	11
5.7.2 Protection Methods	12
6. Manufacturing Information	13
6.1 Soldering	13
6.2 Washing	13
6.3 Mechanical Dimensions	13
6.4 Tape and Reel Specification	14

1. Specifications

1.1 Package Pinout

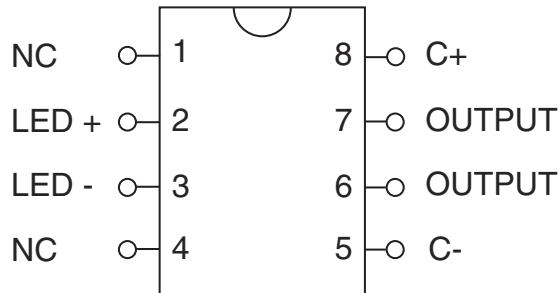

1.2 Pin Description

Pin#	Name	Description
1	NC	Not connected
2	LED +	Positive input to LED
3	LED -	Negative input to LED
4	NC	Not connected
5	C-	External Capacitor, Negative Terminal
6	OUTPUT	Switch Output
7	OUTPUT	Switch Output
8	C+	External Capacitor, Positive Terminal

1.3 Absolute Maximum Ratings

Parameter	Rating	Units
Blocking Voltage (V_L)	60	V_P
Reverse Input Voltage	5	V
Input LED Current		
Continuous	50	mA
Peak (10ms)	1	A
Input Control Current	10	mA
Peak Turn-On Energy Dissipation		
AC/DC Configuration (85°C)	0.67	mJ
DC-Only Configuration (85°C)	1.34	
dV/dt Fault Tolerance		
AC/DC Configuration	160	$V/\mu s$
DC-Only Configuration	80	
Total Power Dissipation ¹	800	mW
Output Power Dissipation	787	mW
Isolation Voltage (Input to Output)	3750	V_{rms}
Operating Temperature	-40 to +85	°C
Storage Temperature	-40 to +125	°C

¹ Derate Total Power linearly by 7.5mW/°C.

Absolute maximum electrical ratings are at 25°C, unless otherwise specified.

Absolute maximum ratings are stress ratings. Stresses in excess of these ratings can cause permanent damage to the device. Functional operation of the device at conditions beyond those indicated in the operational sections of this data sheet is not implied.

1.4 ESD Rating

ESD Rating (Human Body Model)
1000 V

1.5 Recommended Operating Conditions

Parameter	Symbol	Configuration	Min	Typ	Max	Units
Load Current, Continuous	I_L	AC/DC	-	-	300	$\text{mA}_{\text{rms}}/\text{mA}_{\text{DC}}$
		DC-Only	-	-	600	mA_{DC}
Input Control Current	I_F	-	2.5	-	10	mA
Load Voltage	V_L	-	10	-	-	V
External Storage Capacitor	C_{EXT}	-	2	-	6	nF
Load Inductance ¹	$L_{\text{LOAD,AC}}$	AC/DC	-	-	3.0	mH
	$L_{\text{LOAD,DC}}$	DC-Only	-	-	1.75	
Operating Temperature	T_A		-40	-	+85	°C

¹ Maximum load inductance corresponds to a maximum load capacitance. If a TVS or other protection method is used, then no maximum load inductance applies.

1.6 Typical Configurations

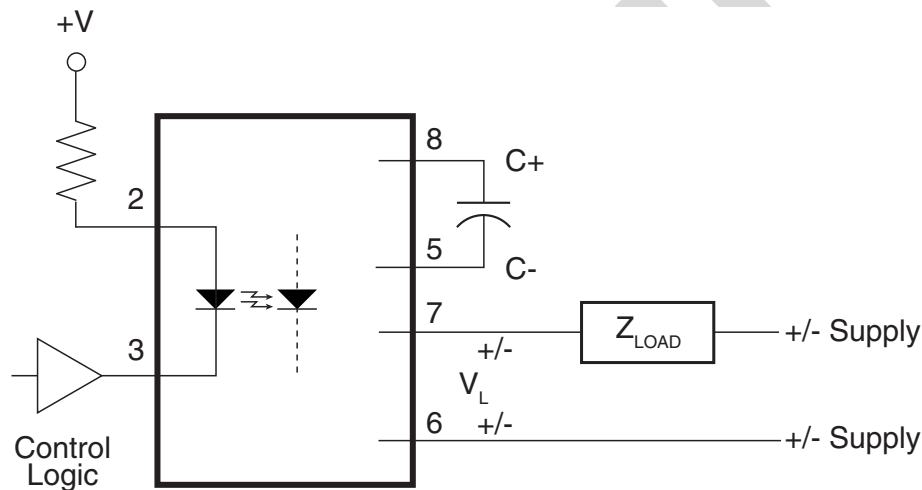

AC/DC Application

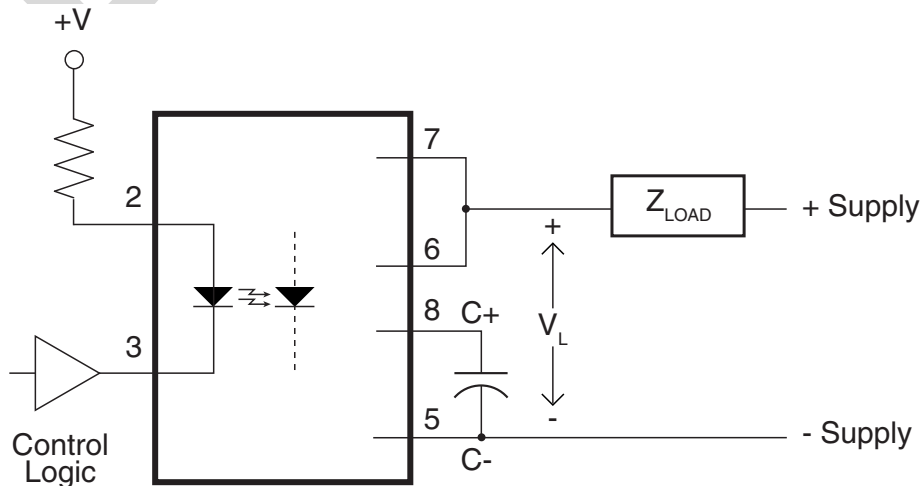

DC-Only Application

1.7 General Conditions

Unless otherwise specified, minimum and maximum values are guaranteed by production testing at 25°C only.

Typical values are characteristic of the device at 25°C and are the result of engineering evaluations. They are

provided for informational purposes only and are not part of the manufacturing testing requirements.

Operating temperature range: $T_A = -40^{\circ}\text{C}$ to $+85^{\circ}\text{C}$

1.8 Electrical Specifications

Parameter	Conditions	Symbol	Min	Typ	Max	Units
Output Characteristics @ 25°C						
Current Limit						
AC/DC Configuration	$I_F=5\text{mA}, V_L=\pm 4\text{V}, t=2\text{ms}$	I_{LMT}	470	614	900	mA_P
DC-Only Configuration	$I_F=5\text{mA}, V_L=4\text{V}, t=2\text{ms}$		1.0	1.2	1.5	A
On-Resistance						
AC/DC Configuration	$I_F=5\text{mA}, I_L=100\text{mA}$	R_{ON}	-	3.9	5.6	Ω
DC-Only Configuration			-	1.09	1.4	
Off-State Leakage Current	$V_L=60\text{V}$	I_{LEAK}	-	-	1	μA
Switching Speeds						
Turn-On	$I_F=5\text{mA}, I_L=100\text{mA}, V_L=10\text{V}$	t_{ON}	-	18	100	μs
Turn-Off		t_{OFF}	40	88	400	
Output Capacitance, AC Configuration	$I_F=0\text{mA}, V_L=1.0\text{V}$	C_O	-	220	-	pF
Thermal Shutdown		T_{SD}		130		$^{\circ}\text{C}$
Input Characteristics @ 25°C						
Input Control Current	$I_L=100\text{mA}$	I_F	-	-	1.1	mA
Input Dropout Current	$I_L=100\text{mA}$	I_F	0.1	0.43	-	
LED Forward Voltage	$I_F=5\text{mA}$	V_F	0.9	1.22	1.40	V
Common Characteristics @ 25°C						
Input to Output Capacitance	-	$C_{I/O}$	-	3	-	pF
Thermal Characteristics						
Thermal Resistance, Junction-to-Ambient	-	$R_{\theta JA}$	-	114	-	$^{\circ}\text{C}/\text{W}$

1.9 Timing Diagram

Switching Time Test Circuit

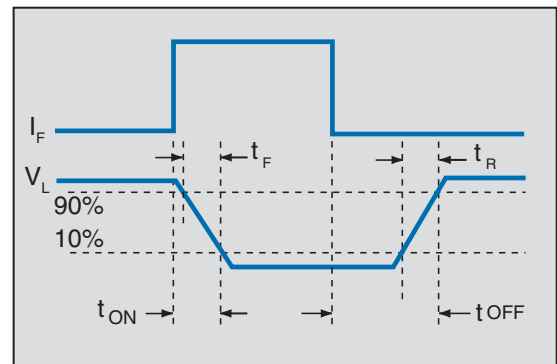
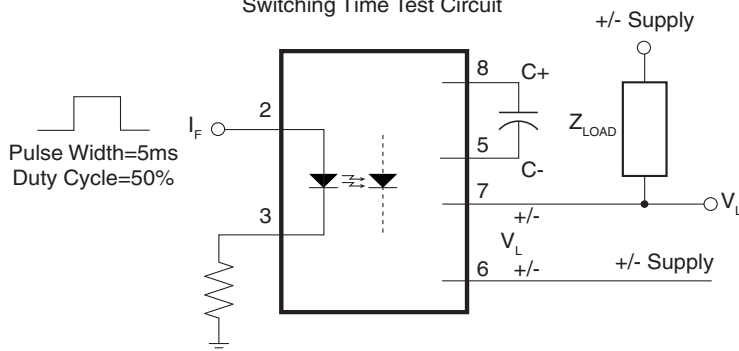

1.10 Performance Data

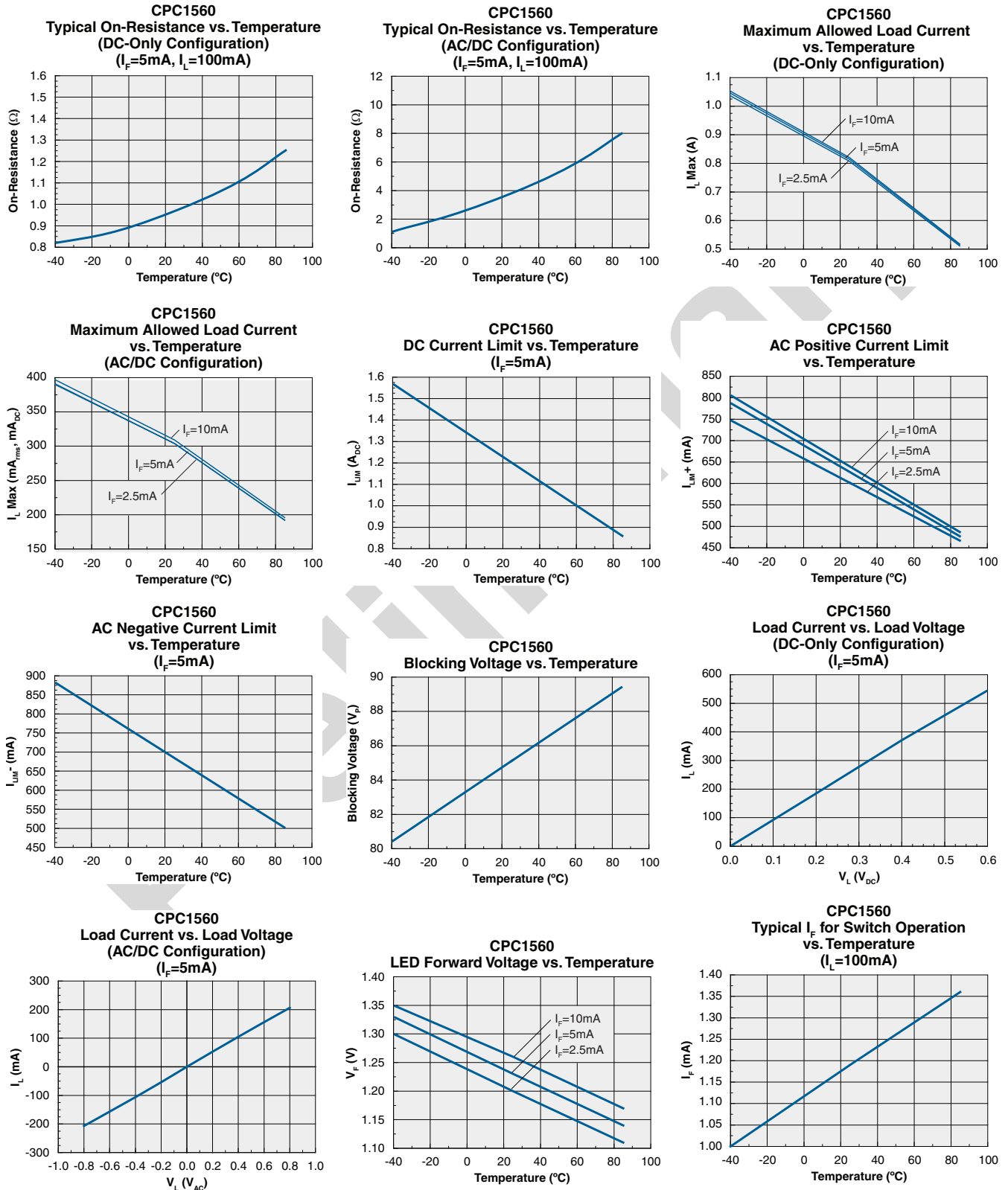

The Performance data shown in the graphs above is typical of device performance. For guaranteed parameters not indicated in the written specifications, please contact our application department.

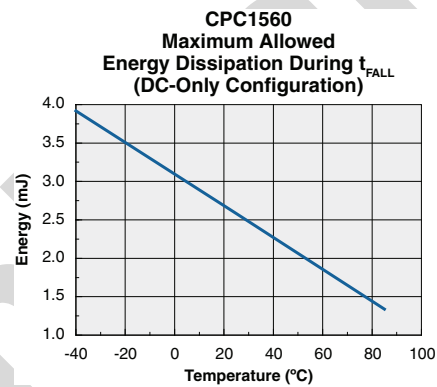
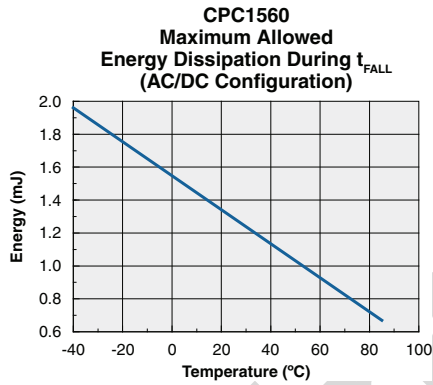
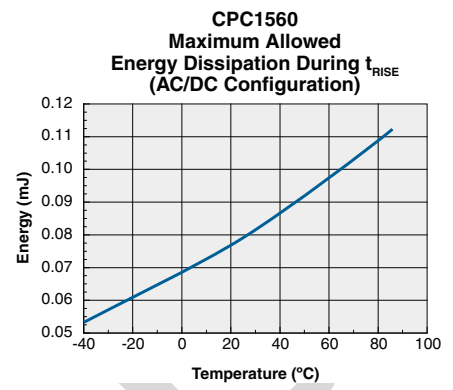
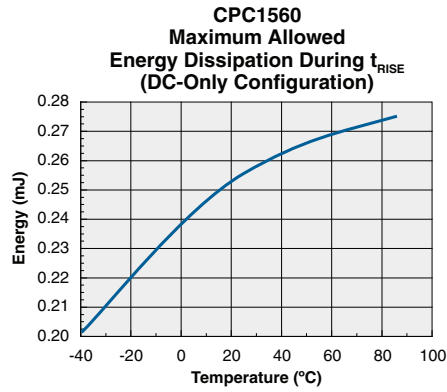
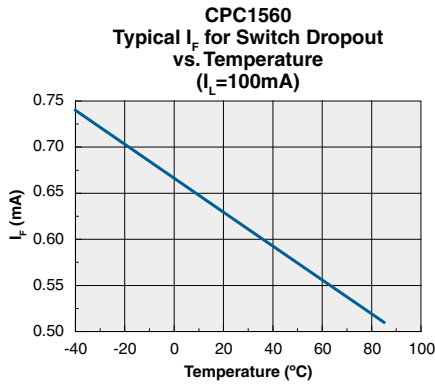

The Performance data shown in the graphs above is typical of device performance. For guaranteed parameters not indicated in the written specifications, please contact our application department.

2. Introduction

The CPC1560 is an optically coupled Solid State Relay (SSR) that is self-biased from the load supply. An external charge storage capacitor is used to greatly speed up SSR turn-on. The CPC1560 also incorporates current limiting and a thermal shutdown feature in the output circuitry, which make the device ideal for use in harsh conditions.

3. Functional Description

Internally, the device is composed of an LED, a photovoltaic array with control circuitry, and two MOSFET output switches.

Input current to the LED is the turn-on signal to the SSR's output MOSFET switches. The LED illuminates the photovoltaics, which provide current to the gates of the output MOSFETs, causing them to conduct. The charge provided to the MOSFET gates initially includes the charge stored in the external capacitor, which causes the SSR to conduct much more quickly than if only the photovoltaic current were used.

When the Load Voltage (V_L) is first applied to the inactive outputs, the external storage capacitor begins to charge. To ensure proper operation, the storage capacitor should be equal to or greater than the total gate capacitance of the two output MOSFET switches. The charge is passed through bootstrap diodes, which prevent the charge from escaping and discharging the capacitor through the MOSFET output switch when the SSR is turned on. The input control current is applied, then the charge is transferred from the storage capacitor through the internal NPN bipolar transistor along with the charge from the photovoltaic, to the MOSFET gates to accomplish a rapid turn-on. After the capacitor has discharged and the MOSFETs have turned on, the photocurrent from the photovoltaic continues to flow into the gates, keeping the MOSFETs turned on.

When the input control current is removed, the gate current stops flowing and the PNP bipolar transistor is on, discharging the MOSFET gates. The MOSFETs are now off. At this point the capacitor begins to recharge for the next turn on cycle.

The non-conducting, optical coupling space between the LED and the photovoltaics provides $3750V_{rms}$ of isolation between the control input and the switched output of the CPC1560.

Important things to note about the operation of the CPC1560:

- The device is designed to maintain its guaranteed operating characteristics with DC input control current (I_F) in the range of 2.5mA to 10mA (see

“Recommended Operating Conditions” on page 4). The device will operate at input currents above and below this range, but device operating characteristics are not guaranteed.

- There is a minimum LED input current required for the device to shut off: typically about 0.43mA at 25°C (see “Electrical Specifications” on page 5).
- The output switch will only withstand a maximum of 60 volts across its terminals before breaking down (see “Absolute Maximum Ratings” on page 3). The maximum voltage generally occurs when the load is off.

The CPC1560 has two different operating configurations: unidirectional DC-only configuration, and bidirectional AC/DC configuration.

In the unidirectional DC-only configuration, the device switches load voltages with a fixed polarity, while in the AC/DC configuration it can switch voltages with either positive or negative polarities.

The advantage of operating the device in the DC-only configuration is the ability to switch larger load currents. The advantage of operating it in the AC/DC configuration is the flexibility of switching load voltages of either polarity.

4. Device Configuration

4.1 LED Resistor

To assure proper operation of the CPC1560, the LED resistor selection should comply with the recommended operating conditions. Although the LED is capable of being operated up to the absolute maximum ratings, this is not recommended. Operating the LED beyond the recommended operating conditions may prevent the current limit and thermal shutdown functions from performing properly. The equation used to calculate the max resistor value:

$$R_{LED_MAX} = \frac{V_{IN_MIN} - V_{LOW_MAX} - V_{F_MAX}}{I_{F_MIN}}$$

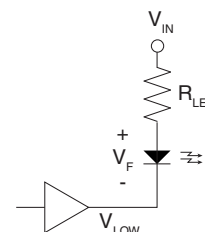

- I_{F_MIN} = Minimum Input Control Current
- V_{IN_MIN} = Minimum Input Power Source
- V_{LOW_MAX} = Maximum Logic Level Low Voltage
- V_{F_MAX} = Maximum Forward Voltage Drop of LED
- R_{LED_MAX} = Maximum Input Resistor to LED

4.2 Storage Capacitor

The CPC1560 requires the use of an external capacitor (C_{EXT}) to meet the device's specifications. This external storage capacitor enables the relay to turn on quickly by holding a reservoir of charge to be transferred to the gates of the MOSFET pair. The capacitor must have a minimum working voltage greater than the load voltage, and must be connected from pin 8 (C+), the capacitor's positive voltage terminal, to pin 5 (C-), the capacitor's negative voltage terminal.

Proper selection of the external capacitor begins with the recommended range provided in the **"Recommended Operating Conditions" on page 4**, and the maximum voltage at the CPC1560 outputs, including transients and faults. The nominal value of the capacitor needs to be chosen so that when the effects of tolerance, temperature coefficient, and (for some types of capacitor) derating due to bias voltage are accounted for, the capacitor's value remains within the recommended range over the operational conditions of the end product.

5. Operational Behavior

5.1 Operating Frequency

5.1.1 Duty Cycle/Power Dissipation

Equation 1 shows the relationship between power dissipation, operating frequency, and duty cycle for the CPC1560 device. From this equation, it can be seen that both switching frequency (f_{switch}) and duty cycle (D) contribute to power dissipation. The first one by generating switching losses, and the second one by generating ON losses. Switching losses are those caused by changes in the energy state of the load components when the device is switching on and off (i.e. E_{RISE} and E_{FALL}), and ON losses are those caused by the flow of current (I_L) through the part's on-resistance (R_{ON}) when it is switched on.

$$(1) P_{avg} = I_L^2 \cdot R_{ON} \cdot D + f_{switch} \cdot (E_{RISE} + E_{FALL})$$

Because a higher operating frequency translates into higher power consumed by the part, care must be taken to limit its value in order to protect the device from exceeding its maximum power rating. When doing this, both the maximum allowed power dissipation in the part and the ON duty cycle, $D = t_{ON} / (t_{ON} + t_{OFF})$, must be taken into consideration.

5.1.2 Temperature Effects

When setting the operating frequency of the CPC1560, the user must also take into account power dissipation over temperature.

5.1.3 Elements of Operating Frequency

In addition to ambient temperature, the maximum frequency of the CPC1560 is also determined by the MOSFET's turn-on and turn-off times and the load voltage rise and fall times as follows:

$$(2) f_{MAX} = \frac{1}{3} (t_{ON} + t_{OFF})^{-1}$$

Where 1/3 is a multiplication factor for temperature and process variations.

5.2 Switching Losses

During the transition intervals of the switching process, the load components change energy states, which results in switching losses as the energy passes through the MOSFETs. This energy transfer is manifested in the form of heat dissipation and must be taken into consideration.

Energy is transferred during the turn-off intervals. This energy, called E_{rise} , will be absorbed by the MOSFET output switches, and if present parasitic load capacitance and the protection device.

Energy is also transferred during the turn-on intervals and is called E_{fall} . This energy will be absorbed by the MOSFET output switches, which is why this energy should be limited to the "peak turn-on energy" values specified in the Absolute Maximum Ratings Table of this datasheet.

The user of the CPC1560 device must understand the details of the load behavior and keep in mind the device's recommended operating conditions in order to adequately size the load components and protect the application circuit.

The average power of the CPC1560 output MOSFET for any specific application and for any load type given by Equation 1 and repeated here is:

$$(3) P_{avg} = I_L^2 \cdot R_{ON} \cdot D + f_{switch} \cdot (E_{RISE} + E_{FALL})$$

From this equation we can see how the switching losses (E_{RISE} and E_{FALL}), together with the "on losses," contribute to the CPC1560's output power dissipation.

The user must also know that the recommended operating conditions for I_L , f_{SWITCH} , load capacitance

(C_{LOAD}) and load Inductance (L_{LOAD}), along with other recommended operating conditions given in this datasheet, are constrained by the 85°C operation of most industrial applications. For lower operating temperature ranges, these values can be de-rated using the information provided in the temperature graphs in this datasheet.

5.2.1 Effects of Ambient Temperature

One of the most important factors is the temperature variation of the environment. From the **Maximum Allowed Energy Dissipation During t_{RISE}** graphs (AC and DC) in this datasheet, the user can see how the energy dissipated in the part during t_{RISE} increases with increasing ambient temperature.

The operating frequency of the device is directly related to the amount of energy dissipated in it during the transition times, t_{RISE} and t_{FALL} , which increases rapidly with temperature, as seen in the previously mentioned graphs. Depending on the operating temperature range of the application, the user must derate the maximum allowed energy in the part during t_{RISE} and t_{FALL} (according to the temperature graphs provided) in order to limit the operating switching frequency.

5.3 Current Limit and Thermal Shutdown

5.3.1 Current Limit

The CPC1560 has a current limit feature in which current through the output switches is limited to a value larger than the recommended operating current.

In the AC/DC configuration, the CPC1560 has bidirectional current limiting, which consists of current limit circuits in both positive and negative polarities. In the DC-only configuration, the DC current limit consists of the parallel of the two AC current limit circuits in the positive DC polarity.

The current limit function has a negative temperature coefficient in which increasing temperature lowers the current limit threshold of the device. Prolonged periods of current limiting will cause the temperature of the device to increase, and, if allowed to continue, will activate the device's thermal shutdown circuitry, forcing the output switches to turn off.

5.3.2 Thermal Shutdown

The purpose of the thermal shutdown feature is to completely shut down the operation of the device when its junction temperature has gone above 130°C, whether this is due to high power dissipation in the device in the form of heat or an increase in the ambient temperature.

The thermal shutdown feature and the current limit feature provide great power cross immunity to the device for improved survivability in harsh environments.

5.4 dV/dt Fault Tolerance

The CPC1560 device has a finite dV/dt fault tolerance for both the AC/DC and DC-only configurations, which must not be exceeded.

The dV/dt tolerance for the device in the AC/DC configuration is double that of the DC-only configuration (see **“Absolute Maximum Ratings” on page 3**). This is because the dV/dt value of the CPC1560 is inversely proportional to the size of the output switch's C_{RSS} , or “reverse transfer capacitance,” and this capacitance in the DC-only configuration is double that in the AC/DC configuration.

5.5 Power Derating

Bear in mind the power rating of the CPC1560 when operating the device at elevated temperatures. The Absolute Maximum Ratings table shows that the maximum allowed power dissipation at 25°C is 800mW, which is the maximum power that can be dissipated before the junction temperature of the device reaches 125°C.

In order to keep the CPC1560 operating within its power rating, use the Maximum Allowed Load Current graphs provided earlier in this document.

5.6 Rise and Fall Times

The CPC1560 has rise and fall times that are primarily limited by internal parasitic elements of the device; the load components only play a secondary role. This can be appreciated in the turn-off graph of an application circuit operating at 45V, where the slope of the load voltage starts scooping down into a more capacitive shape after approximately 15 volts.

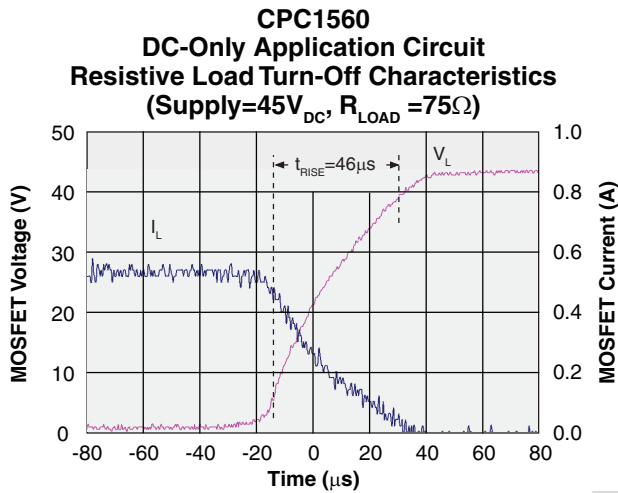

5.7 Over-Voltage Protection

5.7.1 Stored Energy in the Load

During the CPC1560's switching periods, energy is transferred between the load components, the CPC1560 device, and, if used, the over-voltage protection circuitry.

When the output switch turns off, inductive loads (L_{LOAD}) transfer their stored energy into the MOSFET switches, the load capacitance, and the over-voltage protector. (See the turn-off graph for a 45V inductive load application circuit.)

When the output switch turns on, the energy in the load inductor is zero, and the load capacitor (C_{LOAD}) must transfer its stored energy into the MOSFET.

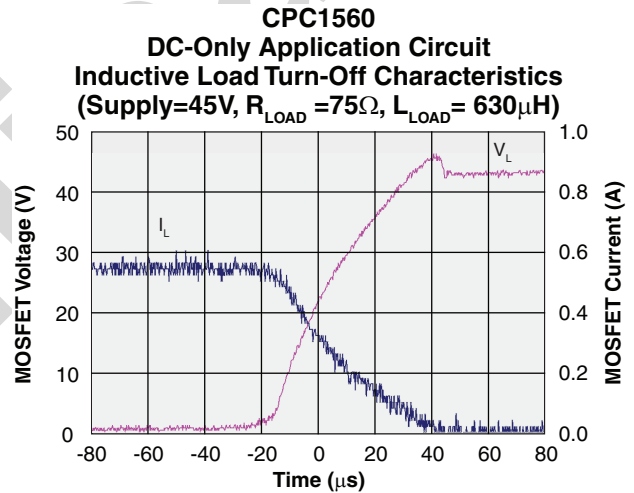

CPC1560

5.7.2 Protection Methods

One way to protect the CPC1560 and application circuit components from damage when excessive stored energy is suddenly released into the output MOSFETs of the CPC1560, is to add a Transient Voltage Suppressor (TVS) across the output switches. Use a unidirectional TVS from the outputs to C- for the DC-only configuration, and use a bidirectional TVS across the output pins for the AC/DC configuration as shown in the diagrams below.

In order to calculate the required TVS value, the user has to compare working voltage of the application circuit to the breakdown voltage of the CPC1560 with the TVS maximum clamping voltage ratings. The TVS maximum clamping voltage capability must be, at a minimum, equal to the specific peak pulse current of the load. This must be done to ensure the TVS can

easily absorb any excess energy coming from the inductive load (L_{LOAD}).

In addition to the TVS, other protection techniques are also available depending on the type of load the user is trying to switch. For purely resistive loads the user may rely on the output transistor to handle any parasitic energy. For very low to moderately inductive loads (e.g. remote switching of a load through a long cable), a voltage suppressor or TVS can be used as explained before. For heavily inductive loads, a fly-back diode connected across the load element is recommended

For much higher inductive loads, other circuit techniques, device ratings and/or protector types must be considered¹. Of paramount importance is that the designer know the characteristics of the load being switched.

Figure 2. CPC1560 DC-Only Configuration with Over-Voltage Protection

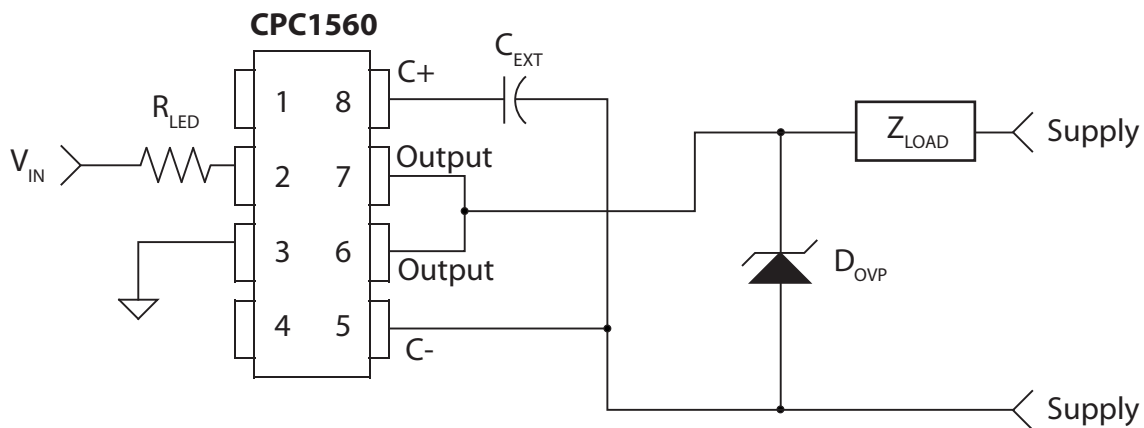
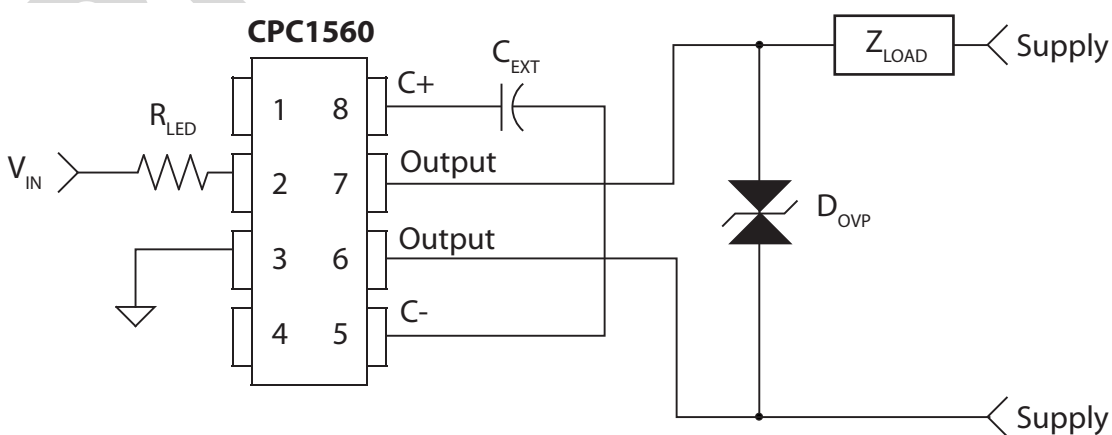

Figure 3. CPC1560 AC/DC Configuration with Over-Voltage Protection



¹ For more over voltage protection techniques consult: Switchmode Power Supply Handbook, 2nd Edition, Keith Billings, ISBN 0-07-006719-8, or Power MOSFET Design, B.E. Taylor, ISBN 0-471-93-802-5

6. Manufacturing Information

6.1 Soldering

For proper assembly, the component must be processed in accordance with the current revision of IPC/JEDEC standard J-STD-020. Failure to follow the recommended guidelines may cause permanent damage to the device resulting in impaired performance and/or a reduced lifetime expectancy.

6.3 Mechanical Dimensions

8-Pin DIP Through-Hole Package

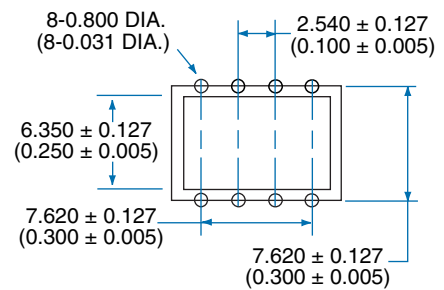
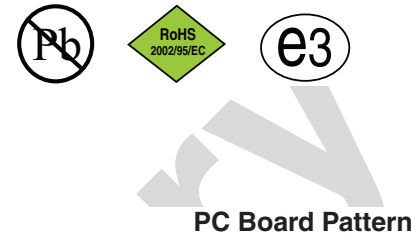
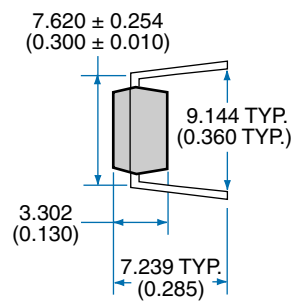
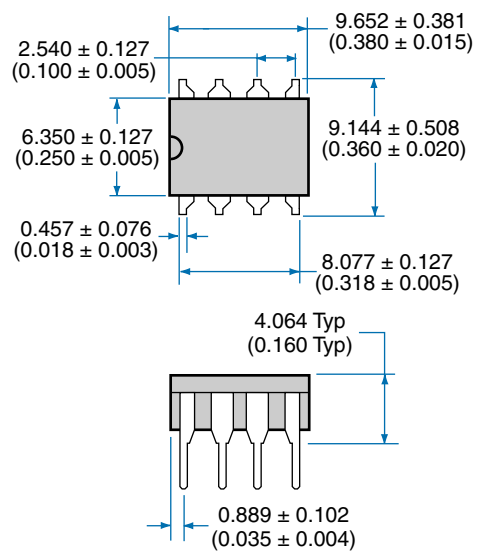

Dimensions
mm
(inches)

8-Pin Surface Mount Package

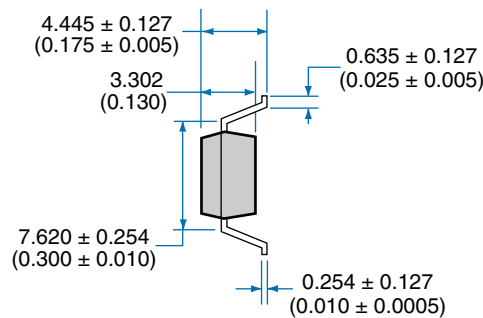
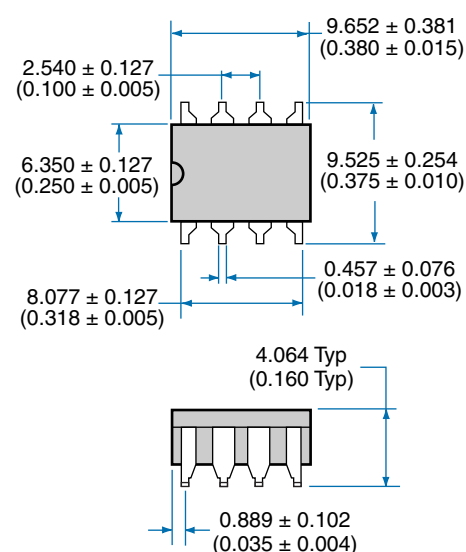

Recommended PCB Land Pattern

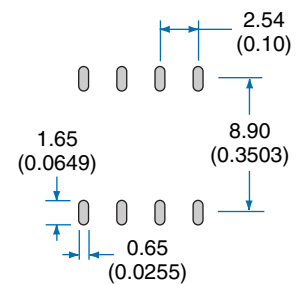

Dimensions
mm
(inches)

6.4 Tape and Reel Specification

Tape and Reel Packaging for 8-Pin Surface Mount Package

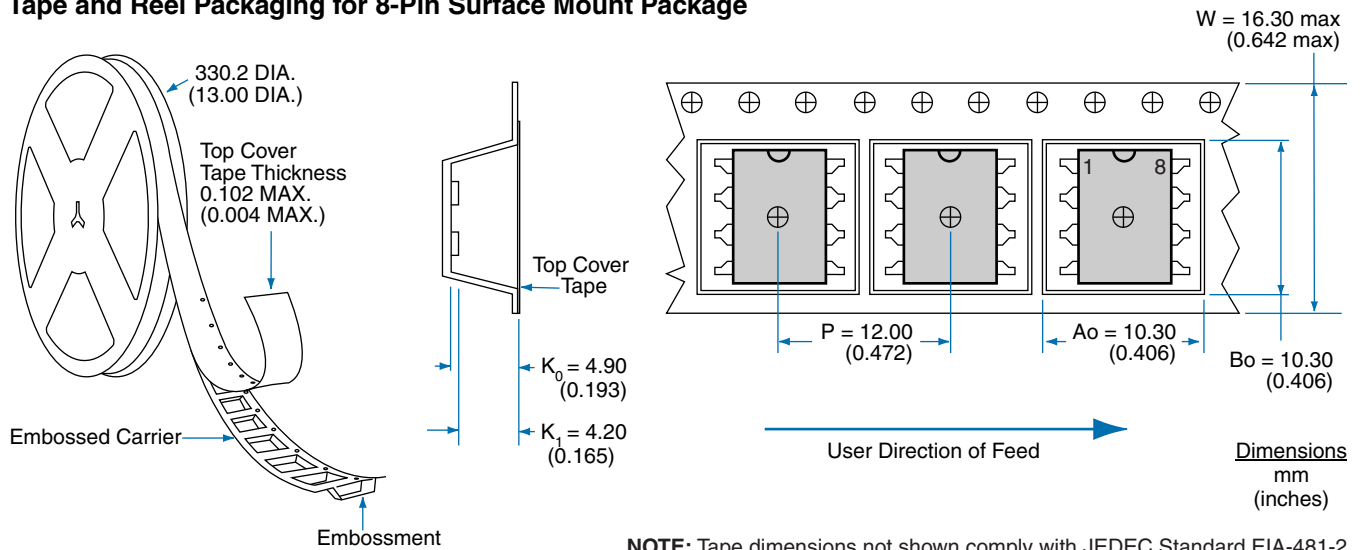

For additional information please visit our website at: www.clare.com

Clare, Inc. makes no representations or warranties with respect to the accuracy or completeness of the contents of this publication and reserves the right to make changes to specifications and product descriptions at any time without notice. Neither circuit patent licenses nor indemnity are expressed or implied. Except as set forth in Clare's Standard Terms and Conditions of Sale, Clare, Inc. assumes no liability whatsoever, and disclaims any express or implied warranty, relating to its products including, but not limited to, the implied warranty of merchantability, fitness for a particular purpose, or infringement of any intellectual property right.

The products described in this document are not designed, intended, authorized or warranted for use as components in systems intended for surgical implant into the body, or in other applications intended to support or sustain life, or where malfunction of Clare's product may result in direct physical harm, injury, or death to a person or severe property or environmental damage. Clare, Inc. reserves the right to discontinue or make changes to its products at any time without notice.

Specification: DS-CPC1560-R00E
©Copyright 2008, Clare, Inc.
All rights reserved. Printed in USA.
6/2/08